

# Sporting and Technical Regulations

**PORSCHE**

**PAYCE  
CARRERA CUP  
AUSTRALIA**



## 2020 Porsche PAYCE Carrera Cup Australia Series

### Sporting and Technical Regulations



Version 1

Published 12/02/2020

## 2020 Porsche PAYCE Carrera Cup Australia Series Sporting & Technical Regulations

<b>S1</b>	<b>TITLE AND JURISDICTION</b> .....	<b>5</b>
	S1.1 Title.....	5
	S1.2 Authority / Jurisdiction .....	5
<b>S2</b>	<b>ADMINISTRATION</b> .....	<b>5</b>
	S2.1 Personnel.....	5
<b>S3</b>	<b>COMPETITOR ELIGIBILITY</b> .....	<b>6</b>
<b>S4</b>	<b>AUTOMOBILE ELIGIBILITY</b> .....	<b>6</b>
	S4.1 Replacement Automobiles .....	6
<b>S5</b>	<b>DRIVER ELIGIBILITY</b> .....	<b>6</b>
	S5.1 Driver Classification .....	6
	S5.2 Substitute Driver .....	6
<b>S6</b>	<b>SERIES ROUNDS / REGISTRATION</b> .....	<b>6</b>
<b>S7</b>	<b>SERIES CALENDAR</b> .....	<b>7</b>
<b>S8</b>	<b>ROUND FORMAT</b> .....	<b>7</b>
	S8.1 Round Format.....	7
	S8.2 Variations to Timetable .....	7
<b>S9</b>	<b>GRID DETERMINATION</b> .....	<b>7</b>
	S9.1 Grid Determination .....	7
	S9.2 Driver Qualification .....	8
<b>S10</b>	<b>START PROCEDURE</b> .....	<b>8</b>
<b>S11</b>	<b>AWARDS AND POINTSCORE</b> .....	<b>8</b>
	S11.1 Prizes and Trophies .....	8
	S11.2 Series Pointscore .....	8
	S11.3 Endurance Cup .....	9
<b>S12</b>	<b>EVENT OPERATIONS</b> .....	<b>10</b>
	S12.1 Series Registration and Entry .....	10
	S12.2 Driver/Team Manager Briefings .....	10
	S12.3 Impound/Parc Fermé .....	10
	S12.4 Practice.....	11
	S12.5 Qualifying .....	11
	S12.6 Warm Up .....	12
	S12.7 Pit Lane .....	12
	S12.8 Removal of Automobiles from the Circuit .....	12
	S12.9 Radio Communication to/from Automobile.....	12
	S12.10 Race Management Channel (RMC).....	12
	S12.11 Lap Triggers .....	12
<b>S13</b>	<b>TYRES</b> .....	<b>13</b>
	S13.1 Tyre Regulations .....	13
	S13.2 Table New tyre usage .....	15
	S13.3 Table Previously nominated tyre usage.....	15
<b>S14</b>	<b>FUEL</b> .....	<b>15</b>

<b>S15</b>	<b>AUTOMOBILE MARKINGS</b>	<b>16</b>
S15.1	Exclusivity	16
S15.2	Automobile Markings and Series Identification	16
S15.3	Competition Numbers	17
<b>S16</b>	<b>DRIVER APPAREL</b>	<b>17</b>
S16.1	Standard of Apparel	17
S16.2	Reserved Signage on Racing Overalls	17
<b>S17</b>	<b>TESTING</b>	<b>17</b>
S17.1	Testing Restrictions	17
S17.2	Pre testing Procedures	17
<b>S18</b>	<b>RAIN LIGHT</b>	<b>18</b>
<b>S19</b>	<b>IN-CAR CAMERAS</b>	<b>18</b>
S19.1	VBox Video HD2 Camera System	18
S19.2	TV Production Cameras	18
<b>S20</b>	<b>GROUND CLEARANCE</b>	<b>18</b>
<b>S21</b>	<b>ABS</b>	<b>19</b>
<b>S22</b>	<b>TELEMETRY, DATA RECORDING SYSTEMS</b>	<b>19</b>
<b>S23</b>	<b>DRY TO WET PROCEDURE</b>	<b>19</b>
<b>S24</b>	<b>PASSENGER RIDES</b>	<b>20</b>
<b>S25</b>	<b>PORSCHE PAYCE CARRERA CUP AUSTRALIA CODE OF CONDUCT</b>	<b>20</b>
<b>APPENDIX 1</b>		<b>22</b>
<b>APPENDIX 2</b>		<b>23</b>
<b>APPENDIX 3</b>		<b>24</b>
<b>T1</b>	<b>PREAMBLE</b>	<b>25</b>
<b>T2</b>	<b>ELIGIBILITY</b>	<b>25</b>
T2.1	Eligible Automobiles	25
T2.2	Examination for Eligibility	25
<b>T3</b>	<b>SCRUTINY</b>	<b>26</b>
T3.1	Onus on Competitor	26
T3.2	Targeted Scrutiny	26
<b>T4</b>	<b>COCKPIT</b>	<b>26</b>
T4.1	Safety Cage	26
T4.2	Windscreen	26
T4.3	Pit Lane Speed Limiter (Limiter)	26
T4.4	Seat	26
T4.5	Safety Harness	27
T4.6	Window Net	27
T4.7	Cool Suit Associated Components	27
T4.8	Drink Bottle	27
T4.9	In-Car Cameras	27
T4.10	Timing Transmitter	27
T4.11	Fire Extinguisher	27
T4.12	Side and rear windows	28
T4.13	Coachwork	28

T4.14	Ventilation .....	28
T4.15	Air Intake Blanking .....	28
<b>T5</b>	<b>TRANSMISSION/DIFFERENTIAL .....</b>	<b>28</b>
<b>T6</b>	<b>ENGINE TYPE .....</b>	<b>28</b>
<b>T7</b>	<b>ENGINE AND TRANSMISSION REPAIRS .....</b>	<b>28</b>
T7.1	Duty of Notification .....	28
T7.2	Repairs .....	29
<b>T8</b>	<b>SEALS .....</b>	<b>29</b>
<b>T9</b>	<b>SUSPENSION .....</b>	<b>29</b>
T9.1	Suspension .....	29
T9.2	Dampers and Springs .....	30
T9.3	Ground Clearance .....	30
T9.4	Anti-Roll bars .....	31
<b>T10</b>	<b>BRAKES .....</b>	<b>31</b>
<b>T11</b>	<b>TELEMETRY, DATA RECORDING SYSTEM AND ECU .....</b>	<b>31</b>
T11.1	Telemetry .....	31
T11.2	Data Recording System .....	31
T11.3	ECU and Wiring Loom .....	31
T11.4	Verification – ECU Data Monitor .....	32
<b>T12</b>	<b>WHEELS .....</b>	<b>32</b>
<b>T13</b>	<b>RACING WEIGHT .....</b>	<b>32</b>
<b>T14</b>	<b>LUBRICANTS .....</b>	<b>33</b>
T14.1	Engine Oil .....	33
T14.2	Gearbox Oil .....	33
T14.3	Oil Samples .....	33
<b>T15</b>	<b>FUEL SYSTEM .....</b>	<b>33</b>
<b>T16</b>	<b>REAR SPOILER .....</b>	<b>34</b>
<b>T17</b>	<b>FRONT LIP .....</b>	<b>34</b>
<b>T18</b>	<b>EXHAUST SYSTEM .....</b>	<b>34</b>
<b>T19</b>	<b>COOLING SYSTEM .....</b>	<b>34</b>
<b>T20</b>	<b>STEERING .....</b>	<b>35</b>
<b>APPENDIX 1</b>	<b>.....</b>	<b>36</b>
<b>APPENDIX 2</b>	<b>.....</b>	<b>40</b>
<b>APPENDIX 3</b>	<b>.....</b>	<b>41</b>
<b>APPENDIX 4</b>	<b>.....</b>	<b>42</b>
<b>APPENDIX 5</b>	<b>.....</b>	<b>43</b>
<b>APPENDIX 6</b>	<b>.....</b>	<b>44</b>
<b>APPENDIX 7</b>	<b>.....</b>	<b>45</b>

# 2020 Porsche PAYCE Carrera Cup Australia Series

## Sporting Regulations

### S1 TITLE AND JURISDICTION

#### S1.1 Title

This Series shall only be known as and referred to as the 2020 Porsche PAYCE Carrera Cup Australia.

#### S1.2 Authority / Jurisdiction

- (a) Each Event in the 2020 Porsche PAYCE Carrera Cup Australia Series (Series) shall be conducted under the provisions of the FIA International Sporting Code including Appendices; the National Competition Rules (NCR) and Circuit Race Standing Regulations (CRSR) of Motorsport Australia; the Sporting and Technical Regulations issued for this Series by Motorsport Australia; Supplementary and Further Regulations issued by the Organiser for each round; Bulletins issued by the Stewards and any Driver Briefing Notes and instructions issued by the Race Director or the Clerk of the Course at an Event.
- (b) This Series has been sanctioned by Motorsport Australia as a National Series.
- (c) Porsche Cars Australia Pty Ltd (PCA) has been appointed as the Category Manager (CM) by Motorsport Australia for this Series.

**Contact Details:** Porsche Cars Australia Pty Ltd (ABN 67 004 327 048)  
Troy Bundy  
109-111 Victoria Parade  
Collingwood VIC 3066  
Tel: (03) 9473 0941  
Fax: (03) 9415 7906

### S2 ADMINISTRATION

#### S2.1 Personnel

- (a) The following personnel have been appointed to the Series by Motorsport Australia and/or the CM and have the authority to administer the various aspects of these regulations as detailed in the CRSR.

(i) Race Director (RD)	David Mori
(ii) Deputy Race Director (DRD)	Jessica Nicholson
(iii) Technical Delegate (TD)	Stephen Robertson
(iv) Driving Standards Advisor (DSA)	Cameron McConville
(v) Category Administrator	Troy Bundy

### **S3 COMPETITOR ELIGIBILITY**

To be eligible to compete in the Series, each Competitor must hold a current Motorsport Australia Competitor Licence and be a party to a current Participation Agreement with the CM.

### **S4 AUTOMOBILE ELIGIBILITY**

Each Automobile must comply with the provisions of the 2020 Porsche PAYCE Carrera Cup Australia Series Technical Regulations to be eligible to compete in the Series. Each Automobile must be registered with the CM and must be the subject of a current Race Vehicle Authorisation Certificate (RVAC) issued by PCA.

#### **S4.1 Replacement Automobiles**

Following the commencement of the first practice session of each round of the Series, any Automobile that has been entered to compete at that round may not be replaced with another Automobile.

### **S5 DRIVER ELIGIBILITY**

To be eligible to compete in the Series, a Driver must be a minimum of 17 years of age and hold a current Motorsport Australia National Circuit Licence (NC) or higher.

#### **S5.1 Driver Classification**

- (a) Each Driver shall be assessed by the CM prior to entering the Series and shall be deemed to be one of the following classifications for the purpose of awarding class points:
  - (i) Outright/Pro
  - (ii) Pro-Am
- (b) Each Driver shall be advised in writing by the CM of their classification.
- (c) A Driver's classification may be changed at any time as determined and advised by the CM.

#### **S5.2 Substitute Driver**

Prior to the commencement of the first qualifying session at each round of the Series, a Competitor may nominate a substitute Driver who may be permitted to compete in the remainder of the Event subject to the approval of the Stewards and the CM.

### **S6 SERIES ROUNDS / REGISTRATION**

- (a) The Series shall be conducted over eight (8) Rounds as detailed in the Series Calendar below.
- (b) Each race conducted as a part of the Series shall count in determining the final results.
- (c) Each Competitor shall be required to be registered with the CM prior to competing in the Series.

## S7 SERIES CALENDAR

The Series shall be conducted over the following Rounds:

Round	Date	Circuit
1	20 – 23 February	Adelaide Parklands
2	12 – 15 March	Albert Park
3 <sup>^^</sup>	26- -28 June	Townsville
4 <sup>^^</sup>	17 – 19 July	Hidden Valley
5 <sup>^^</sup>	28 – 30 August	Sydney Motorsport Park
6 <sup>^^</sup>	18 – 20 September	The Bend Motorsport Park
7 <sup>^^</sup>	8 – 11 October	Mount Panorama
8 <sup>^^</sup>	30 October – 1 November	Surfers Paradise

<sup>^^</sup> Denotes a Round which includes Races counting towards the Endurance Cup

## S8 ROUND FORMAT

The number, length and format of track sessions shall ultimately be negotiated between the CM and the Event Organiser prior to a Round of the Series and shall be advised in the relevant Supplementary/Further Supplementary Regulations issued for an Event.

Generally, the format for each Round of the Series shall be as follows:

### S8.1 Round Format

- (a) Practice - A minimum of thirty (30) minutes of practice time (normally Friday).
- (b) Qualifying - A minimum of twenty (20) minutes of qualifying time (normally Saturday).
- (c) Races - A minimum of seventy (70) minutes of race time shall be scheduled at each Round of the Series as detailed in the relevant Supplementary Regulations.

### S8.2 Variations to Timetable

The timetable may be varied at any time due to exceptional circumstances only with the approval of the Stewards.

## S9 GRID DETERMINATION

### S9.1 Grid Determination

Unless otherwise stated in the Event Supplementary Regulations, the grid for each race shall be determined as detailed in the CRSR – Progressive Grid.

## S9.2 Driver Qualification

Any Driver whose best lap time achieved in a qualifying session exceeds 109% of the fastest lap time achieved in the relevant session shall not be permitted to further compete at that Round of the Series unless approved otherwise by the Stewards due to exceptional circumstances.

## S10 START PROCEDURE

Unless otherwise stated in the Event Supplementary Regulations, the start procedure for each race shall be as detailed in the CRSR – Non-Championship Start – Standing Start except that, where approved by Motorsport Australia, the formation lap may be greater than one lap of the circuit.

## S11 AWARDS AND POINTSCORE

### S11.1 Prizes and Trophies

- (a) Prizes, trophies and awards shall be as determined by the CM and shall be advised to each Competitor.
- (b) The winner of the Series must be present at the annual Motorsport Australia Motor Sport Awards Prize Giving Ceremony. Failure to attend the ceremony by the winner shall be deemed an infringement of these regulations unless prior agreement has been given by Motorsport Australia and may result in the loss of points and/or awards.

### S11.2 Series Pointscore

- (a) Unless otherwise detailed in the Supplementary Regulations, points shall be awarded to Drivers for each race in the Series as follows:

Finish position	Points		Finish position	Points	
	Rounds with 3 Races	Rounds with 4 Races		Rounds with 3 Races	Rounds with 4 Races
1 <sup>st</sup>	60	45	15 <sup>th</sup>	11	9
2 <sup>nd</sup>	54	41	16 <sup>th</sup>	10	8
3 <sup>rd</sup>	48	36	17 <sup>th</sup>	9	7
4 <sup>th</sup>	42	32	18 <sup>th</sup>	8	6
5 <sup>th</sup>	36	27	19 <sup>th</sup>	7	5
6 <sup>th</sup>	32	24	20 <sup>th</sup>	6	4
7 <sup>th</sup>	29	22	21 <sup>st</sup>	5	3
8 <sup>th</sup>	26	20	22 <sup>nd</sup>	4	2
9 <sup>th</sup>	23	17	23 <sup>rd</sup>	3	1
10 <sup>th</sup>	20	15	24 <sup>th</sup>	2	1
11 <sup>th</sup>	18	14	25 <sup>th</sup>	1	1
12 <sup>th</sup>	16	12	26 <sup>th</sup>	1	1
13 <sup>th</sup>	14	11	27 <sup>th</sup>	1	1
14 <sup>th</sup>	12	10	28 <sup>th</sup>	1	1



- (b) In addition to the above, one (1) point shall be awarded to the Driver recording the fastest lap time during Qualifying.
- (c) Points shall only be awarded to the Drivers classified as finishers in the final results of each race.
- (d) Points shall be awarded for the following Classes:
  - (i) Outright/Pro
  - (ii) Pro-Am
- (e) Each Driver who is classified as a finisher in a race shall be awarded Outright points in accordance with the [Table S11.2](#) relative to each other Driver who is classified as a finisher in that race.
- (f) The Driver gaining the highest Outright/Pro points total over the total number of Rounds shall be declared the Winner of the 2020 Porsche PAYCE Carrera Cup Australia Series.
- (g) Each Driver in the Pro-Am Class who is classified as a finisher in a race shall be awarded Pro-Am Class points in accordance with [Table S11.2](#) relative to each other Driver who is classified as a finisher in the Pro-Am Class in that race.
- (h) The Pro-Am Class Driver who accumulates the greatest number of Pro-Am Class points at any seven (7) Rounds shall be the winner of the Pro-Am Class.
- (i) The results for each Class at a Round of the Series shall be determined by the number of points scored by each Driver at that Round. In the event of a tie at the end of any Round of the Series, the final positions for that Round shall be determined by comparing the results of each of the tied Drivers in the final race of that Round. The higher place in the Round results shall be awarded to the Driver with the higher finishing position in the final race.
- (j) In the event of a tie at the end of the Series in any Class, final positions shall be determined by comparing the race results achieved by each tied Driver, with the Driver with the highest number of first places being awarded the higher Series position. If at this stage a tie still exists, it shall be resolved by comparing the number of second, third or fourth places (and so on) achieved by each tied Driver until all positions have been determined.

### **S11.3 Endurance Cup**

- (a) The Endurance Cup shall consist of six (6) x 40/45-minute races across six (6) Rounds as outlined in [Table S7](#).
- (b) Points shall be awarded for the following Classes in accordance with [Table S11.2](#):
  - (i) Outright/Pro
  - (ii) Pro-Am
- (c) Points shall only be awarded to Drivers classified as finishers in the final results of each Endurance Cup race.

- (d) The Outright/Pro Class Driver who accumulates the greatest number of points across the six (6) Endurance Cup races shall be the winner of the Outright/Pro Class.
- (e) The Pro-Am Class Driver who accumulates the greatest number of points across five (5) of the Endurance Cup races shall be the winner of the Pro-Am Class.
- (f) In the event of a tie at the end of the Endurance Cup in any Class, final positions shall be determined by comparing the race results achieved by each tied Driver, with the Driver with the highest number of first places in their Class being awarded the higher Series position in that Class. If at this stage a tie still exists, it shall be resolved by comparing the number of second, third or fourth places in Class (and so on) achieved by each tied Driver until all positions have been determined. If at this stage a tie still exists, the higher position shall be awarded to the Driver with the higher finishing position in the final Endurance Cup race.

## **S12 EVENT OPERATIONS**

### **S12.1 Series Registration and Entry**

The Series shall operate under the Motorsport Australia Series Registration and Entry Process. Series Registration and Entry Forms shall be available from the CM with document checking being conducted by the CM prior to the first official track session at each Round of the Series.

### **S12.2 Driver/Team Manager Briefings**

- (a) Each Driver and Team Manager (i.e. an appropriately authorised representative of the Competitor, other than the Driver) must attend the compulsory Drivers/Team Manager Briefing.
- (b) The time and location of this briefing shall be detailed in the Supplementary or Further Regulations for the Event.
- (c) The attendance sheet must be signed by the Driver and the Team Manager to confirm attendance.
- (d) Other compulsory briefings may be convened as required and shall be advised to each Competitor accordingly.

### **S12.3 Impound/Parc Fermé**

- (a) The location of Parc Fermé for each Round shall be confirmed in the Event Supplementary Regulations or the Team Notes provided by the CM prior to the Event.
- (b) Each Automobile, including those remaining in pit lane, must proceed directly to the designated impound/Parc Fermé area via the most direct route (or as directed by Officials) at the conclusion of qualifying without interference from any third party (other than an Official).
- (c) Each Automobile completing each race must proceed directly to the designated impound/Parc Fermé area via the most direct route (or as directed by Officials) at the conclusion of the race and without interference from any third party (other than an Official).

- (d) One (1) team member per Automobile may be permitted to enter the designated impound/Parc Fermé area for the purpose of checking tyre pressures only. This shall be permitted at the direction of the TD or the Chief Scrutineer only and the team member must leave the impound/Parc Fermé area immediately once the tyre pressure check is completed.
- (e) An Automobile may not be removed from any impound/Parc Fermé except at the direction of the TD or the Chief Scrutineer.

#### **S12.4 Practice**

- (a) The order in which each Automobile proceeds onto the track for the first practice session at Round 1 of the Series shall be determined by the previous year's Series final outright point score followed by any new Drivers to the Series in the Automobile's competition number order.
- (b) The order in which each Automobile proceeds onto the track for the first practice session from Round 2 of the Series onwards shall be determined by the Outright Series point score order at the conclusion of the previous Round.
- (c) The order in which each Automobile proceeds onto the track for the second and subsequent practice sessions at a Round of the Series shall be determined by the lap times achieved from the previous Practice session with the Automobile that achieves the fastest lap time proceeding onto the track first and so on.
- (d) In the event that an Automobile is unable to proceed onto the track in the order specified above, the CM may indicate to the next Automobile to take its place in the order.
- (e) During each practice session each Automobile must park nose in at an angle of approximately 45 degrees in their allocated pit bay when in Pit Lane.
- (f) Any Automobile that enters the Pit Lane or is still in the fast lane after the chequered flag is displayed must remain in the fast lane and proceed to the Parc Fermé or as otherwise directed by an official. No work, including taking tyre pressures, is permitted until the Automobile is in the Parc Fermé.

#### **S12.5 Qualifying**

- (a) The order in which each Automobile proceeds onto the track at the commencement of each qualifying session shall be determined by the lap times achieved in the combined practice sessions at the Event with the Automobile which achieved the fastest lap time proceeding onto the track first and so on.
- (b) In the event that an Automobile is unable to proceed onto the track in the order specified above, the CM may indicate to the next Automobile to take its place in the order.
- (c) During qualifying an Automobile may not return to the paddock/garage area without the express permission of the TD. If an Automobile exits pit lane to the paddock/garage during qualifying it shall not be permitted to re-join that session.

- (d) During each qualifying session each Automobile must park nose in at an angle of approximately 45 degrees in their allocated pit bay when in Pit Lane.
- (e) Teams are not permitted to work on an Automobile in the Pit Lane once the chequered flag has been displayed at the conclusion of a qualifying session unless authorised by the TD.
- (f) Any Automobile that enters the Pit Lane or is still in the fast lane after the chequered flag is displayed must remain in the fast lane and proceed to the Parc Fermé or as otherwise directed by an official. No work, including taking tyre pressures, is permitted until the Automobile is in the Parc Fermé.

### **S12.6 Warm Up**

During each Warm Up session each Automobile must parallel park in their allocated pit bay when in Pit Lane.

### **S12.7 Pit Lane**

- (a) Each Pit Crew member is required to sign a Pit Lane Indemnity Form prior to the first track session and to display identification as and if required by the Organiser.
- (b) Pit Crew members are not permitted to work on competing Automobiles in the “fast lane” at any time, including whilst Automobiles are queued waiting to re-enter the track after a red flag period.

### **S12.8 Removal of Automobiles from the Circuit**

Following the commencement of the first qualifying session, it is not permitted to remove any Automobile from the circuit prior to the release of all Automobiles from the impound/Parc Fermé established following the final race of that Round of the Series without the prior express written approval of the TD.

### **S12.9 Radio Communication to/from Automobile**

Two way radio communications between the Driver and a member of the pit crew is mandatory at all times whilst the Automobile is on the race track.

### **S12.10 Race Management Channel (RMC)**

- (a) A minimum of one (1) senior team member for each competing Automobile must monitor RMC at all times during practice, qualifying or racing.
- (b) This team member must monitor RMC from the time that the marshalling of Automobiles commences prior to their release from the pit/paddock bay until all Automobiles have returned to their allocated pit/paddock bay at the conclusion of Parc Fermé following any practice, qualifying or race.
- (c) All relevant messages received on the RMC must be relayed to the Driver.
- (d) Details of the RMC frequency shall be available from the CM.

### **S12.11 Lap Triggers**

- (a) The use of individual beacons is prohibited.

- (b) The Category beacon shall be placed, where possible, as close to the control line at each circuit for each track session.

## S13 TYRES

### S13.1 Tyre Regulations

- (a) Only the control tyres listed below, complete with barcode identification, are permitted for use in the Series:

	Dry Weather tyres	Wet Weather tyres
Front	Michelin slick tyre – 27/65-18 Porsche Cup N2#	Michelin wet tyre – 27/65-R18 P2L
Rear	Michelin slick tyre – 31/71-18 Porsche Cup N2	Michelin wet tyre – 31/71-R18 P2L

- (b) Only tyres supplied by the following supplier may be used:

**European Technique**

338 Swan Street  
 Richmond VIC 3121  
 Ph: 03 9428 5547  
 Fax: 03 9428 0839

- (c) Each control tyre is allocated to a specific Automobile (identified by its chassis/VIN#) and, with the exception of wear resulting from normal usage, each control tyre must remain unmodified except as detailed below:
- (i) A section of “build up” measuring a maximum of 50mm across the entire tread may be removed from each tyre to allow the tyre tread depth to be measured at a maximum of two (2) locations on any one (1) tyre.
  - (ii) The removal of any additional “build up” to allow closer inspection of a control tyre must not be carried out without the prior express permission of the TD.
  - (iii) Other than as provided in this rule, teams must not remove tyre “build up” from any control tyre during a Round by any means other than by driving.
  - (iv) The removal of tyre ‘build up’ is permitted between each Round.
- (d) The maximum number of new tyres permitted to be used at each Round is detailed in Table [13.2](#) below.
- (e) For the entire Series, 16 (8 front and 8 rear) additional new tyres are allocated to a specific Automobile (identified by its chassis/VIN#) of which up to 4 (2 front and 2 rear) can be used as joker tyres during Practice only at each Round. The use of one (1) or more joker tyres must be announced to the TD prior to the commencement of Practice. If an Automobile does not participate at one or more Rounds, the total number of joker tyres will be reduced by 2 (1 front and 1 rear) for each of these Rounds.
- (f) The number of previously nominated tyres is unlimited but may only be used as per Table [S13.3](#) below.

- (g) A previously nominated tyre is any tyre that has been scanned into the tyre bank for that specific Automobile during the 2020 Series.
- (h) For the first Round of the Series, a maximum of four (4) new or used tyres are permitted to be nominated as a previously nominated tyre. These nominated tyres shall be added to the tyre bank allocated for that specific Automobile.
- (i) The Porsche Cars Australia database of scanned tyres shall be the official record of the 2020 tyre bank for each Automobile.
- (j) There shall be no new replacement control tyres. Any replacement tyre must be marked for that Automobile at that Round of the Series. Permission to use a replacement tyre shall be at the discretion of the TD.
- (k) Any replacement tyre approved for use by an Outright/Pro Class Automobile must be marked for use on that Automobile. That Automobile must then start the next race at that Round from the rear of the grid.
- (l) Any replacement tyre approved for use by a Pro-Am Class Automobile must be marked for use on that Automobile. That Automobile must then start the next race at that Round of the Series with a 2 grid spot penalty. A maximum of 2 front and 2 rear tyres can be replaced at a Round of the Series and a maximum of 4 front and 4 rear tyres may be replaced for the Series. Any further replacement tyres shall result in that Automobile starting the next race at that Round of the Series from the rear of the grid.
- (m) Each new control tyre must only be mounted with the barcode facing outwards unless authorised by the TD. The TD shall only authorise a tyre to be “turned” on the rim if they deem it is otherwise not useable. Any previously nominated tyre is free to be mounted in either direction.
- (n) It is not permitted to use any device or chemical treatment which artificially varies the temperature in or of a control tyre, regardless of whether the control tyre is mounted on a wheel or not.
- (o) The official tyre supplier shall have one (1) set of new wet tyres available for each Automobile at each Round of the Series. From the commencement of any session requiring the use of wet tyres a maximum of two (2) sets of wet tyres may be used at that Round of the Series. These tyres may be allocated to that Automobile’s tyre bank.
- (p) Each control tyre must only be allocated to a specific Automobile, identified by its chassis/VIN number, and no control tyre may be transferred between Automobiles. Should an Automobile be transferred or sold, the control tyres allocated to that Automobile must also be transferred or sold so as they remain allocated to such Automobile.

**S13.2 Table New tyre usage**

Round	Practice	Qualifying and Races
1	16 Joker Tyres	8
2		12
3		8
4		8
5		8
6		8
7		8
8		8

**S13.3 Table Previously nominated tyre usage**

Round	Practice	Warm Up	Qualifying and Races
All	Yes	Yes	No

**Please note:** The TD shall be sole arbiter with regard to the interpretation and application of these tyre regulations and any decision made by the TD in this regard shall not be the subject of any protest or appeal.

**S14 FUEL**

- (a) For the duration of an Event, each Competitor must only use the specified control fuel supplied by the official fuel supplier as detailed below or their appointed representative:

Race Fuels

Mark Tierney

BH: 0419 511 517

Email: info@racefuels.com.au

- (b) Approved containers as supplied by the Fuel Supplier and as detailed in [Appendix 2](#) must be used.
- (c) Any container used for storing or handling fuel must have the Hazard information as detailed in [Appendix 2](#) affixed.
- (d) With the exception of ambient atmospheric air and the specified control fuel, no other substance may be added to the intake charge of the engine.
- (e) During the re-fuelling, only the following personnel that are participating in the re-fuelling shall be permitted in the garage area surrounding the Automobile.
- (i) A maximum of two (2) refuellers of which one is a fire attendant.
  - (ii) The fire attendant must be in attendance during refuelling/decanting and must be dressed in accordance with the Schedule D Article 3.6(b).



## S15 AUTOMOBILE MARKINGS

### S15.1 Exclusivity

- (a) It is prohibited to communicate advertising on an Automobile of any company or product that is in competition to Porsche Cars Australia, Porsche Motorsport global partners or the Series' title partner unless otherwise advised in writing by the CM.
- (b) The current status of official Series and cooperation partners can be requested from the CM.

### S15.2 Automobile Markings and Series Identification

- (a) In addition to the requirements detailed below and [Appendix 1](#) of these regulations, each Automobile must comply with Schedule K of the Motorsport Australia Manual unless specifically approved by Motorsport Australia.
- (b) Each Competitor must display the Series sponsor decals as detailed in the table below and [Appendix 1](#) of these regulations.
- (c) The Series sponsor decals shall be supplied by the CM.
- (d) Any signage placed on an Automobile in the direct view of a TV Production on-board camera must have the prior written approval of the CM.

Reference Number	Quantity	Size (mm)	Symbol	Car Position
1	1	120 x 557	MICHELIN	Centre / Top front bumper
1A	2	200 high	Competition Number Pro = Orange Pro-Am = Yellow	Right-side front windscreen / Left-side rear windscreen
2	1	70 x 55	PORSCHE crest	Original position front bonnet
3	2	70 x 290	MOBIL 1	Left and Right front bumper
4	2	110 x 110	Reserved PCA	Left and Right front bumper
5	2	110 x 110	Reserved PCA	Left and Right front bumper
6	2	80 high	Driver's Surname	Left and Right door window
7	2	110 x 110	Reserved PCA	Left and Right side rear view mirrors
8A	1	30 high	www.porsche.com.au	A' pillar (Non-Driver's side)
8B	1	30 high	www.carreracup.com.au	A' pillar (Driver's side)
9	1	61 x 275	MOBIL 1	Rear bumper, affixed on delivered number plate
10	2	45 high letters	Driver Classification	Left and Right rear side window
11	2	60 x 190	Coffex	Left and Right rear side panel above sill
12	2	100 high	Competition Number Pro = Orange Pro-Am = Yellow	Left and Right rear side window
13	2	142 x 210	Reserved PCA	Left and Right rear wing end plate
14	2	61 x 361	MICHELIN	Left and Right of rear number plate
16	1	30 x 260	PORSCHE & GT3 CUP	Original position, centre rear panel
17	2	60 x 260	Reserved PCA	Left and Right sill
18	2	60 x 260	Reserved PCA	Left and Right sill
19	2	60 x 260	Reserved PCA	Left and Right sill
20	2	60 x 260	Reserved PCA	Left and Right sill
21	2	60 x 260	Reserved PCA	Left and Right sill
22	2	60 x 260	Motorsport Australia	Left and Right sill
23	2	400 x 400	Reserved PCA	Left and Right front bumper
24	2		Reserved PCA	Left and Right headlight
25	2		Reserved PCA	Left and Right daytime running light
26	1	200 high	PAYCE	Front top windscreen banner
27	1	160 high	PAYCE	Rear top windscreen banner



### S15.3 Competition Numbers

The allocation of a competition number for each Automobile is solely the responsibility of the CM, which shall maintain a register of all competition numbers allocated to, or reserved for, any Automobile.

## S16 DRIVER APPAREL

### S16.1 Standard of Apparel

Each Driver must wear apparel that complies with “International” in Table 1.1 of Schedule D of the Motorsport Australia Manual.

### S16.2 Reserved Signage on Racing Overalls

Each Driver is required to have signage as detailed below affixed to their racing overalls.

**PORSCHE PAYCE CARRERA CUP AUSTRALIA**  
 SEASON 2019 | Race Suit Signage Regulations



## S17 TESTING

### S17.1 Testing Restrictions

Unless approved by the CM in writing, testing of any competition Automobile and/or Driver deemed to be associated with the Series is not permitted on any circuit during the seven (7) days preceding a Round of the Series at that circuit, other than private sessions sanctioned by the CM. For clarification, the seven days commences at 0001 hours on the Saturday preceding the scheduled Round.

### S17.2 Pre testing Procedures

- (a) Before any Team may undertake testing it is their responsibility to:
  - (i) Notify the CM ([motorsport@porsche.com.au](mailto:motorsport@porsche.com.au)) in writing no less than five (5) working days before the date of the proposed test.
  - (ii) Obtain permission from the CM to conduct a Test day; which permission shall not be unreasonably withheld.

## **S18 RAIN LIGHT**

The rain light fitted to each Automobile must be illuminated at all times when the Automobile is running on wet-weather tyres or as directed by the RD.

## **S19 IN-CAR CAMERAS**

### **S19.1 VBox Video HD2 Camera System**

- (a) Each Automobile must be fitted with a VBox Video HD2 camera system.
- (b) It is not permitted to fit any additional on-board camera.
- (c) Each Competitor shall be required to ensure that the camera is switched on and functioning in the correct manner prior to the Automobile entering the Circuit for each practice, Passenger Ride, qualifying, warm up and racing session at an Event.
- (d) Access to the camera must be provided to the CM appointed technicians at any time upon request.
- (e) No person other than the authorised CM appointed technicians shall interfere with the camera, other than to remove and replace the USB storage device.
- (f) When requested, a Team must immediately provide the USB storage device to the DSA or RD upon request.
- (g) The USB storage device must be clearly identified with the Automobile's Competition Number.
- (h) A Team is not permitted to remove the USB storage device while the Automobile is under Parc Fermé conditions.

### **S19.2 TV Production Cameras**

- (a) The CM reserves the right to install TV production in-car and on-board cameras on an Automobile and position signage within view of the camera.
- (b) Teams shall be allocated signage area within view of the TV production in-car camera as per [Appendix 3](#) which must be approved by the CM.

## **S20 GROUND CLEARANCE**

- (a) It is forbidden to adjust the ride height of an Automobile by altering the static length of the front or rear spring during a qualifying session of an Event.
- (b) Any Competitor or team member found adjusting the ride height of the Automobile during a qualifying session of an Event shall result in a penalty of disqualification of the Automobile from that session being imposed.

## **S21 ABS**

- (a) ABS is not permitted.
- (b) Each automobile must be fitted with the ABS dummy block – part number MTH355335.

## **S22 TELEMETRY, DATA RECORDING SYSTEMS**

- (a) At any time during an Event, the TD and/or Stewards have the right to request and receive from a Competitor or Automobile, recorded Automobile data. This data may be analysed and provided to the Stewards for use as evidence in inquiries and hearings.
- (b) The use of any laptop/computer connected to the Automobile is forbidden during any Qualifying session and Race from the time the Automobile enters the marshalling area until the Automobile is released from Parc Fermé.

## **S23 DRY TO WET PROCEDURE**

- (a) Prior to the Automobiles being called to the marshalling area, if the circuit is declared wet prior to the Automobiles being called to the marshalling area, Articles S23 (b) and (c) shall not apply.
- (b) Before the race start
  - (i) In the event of the circuit conditions changing from dry to wet, to the point that wet tyres are required, after the Automobiles have left the marshalling area but prior to the race start, all Automobiles shall be directed to the Pit Lane.
  - (ii) The only work permitted to be carried out on an Automobile while in the Pit Lane shall be changing to wet tyres.
  - (iii) On completion of all Automobiles changing to wet tyres, each Automobile shall proceed to the grid as instructed over RMC.
- (c) During the race
  - (i) In the event of the circuit conditions changing from dry to wet, to the point that wet tyres are required during the race, the Safety Car shall be deployed.
  - (ii) If it is determined that the track will not dry quickly and less than 75% of the race distance has been completed, the race shall be suspended with all Automobiles directed to the Pit Lane.
  - (iii) The only work permitted to be carried out on an Automobile in the Pit Lane shall be changing to wet tyres.
  - (iv) On completion of all Automobiles changing to wet tyres, the order in which Automobiles are to line up behind the Safety Car at pit exit shall be announced over RMC.

- (v) The start procedure for resuming the race shall be as detailed in CRSR 6.14(i) – Resuming the Race.
- (vi) If it is determined that the track will not dry quickly and 75% or more of the race distance has been completed, the race shall be stopped and not restarted.

## **S24 PASSENGER RIDES**

Any passenger rides conducted must comply with the Motorsport Australia MSPRA Policy.

## **S25 PORSCHE PAYCE CARRERA CUP AUSTRALIA CODE OF CONDUCT**

- (a) The Porsche PAYCE Carrera Cup Australia is a racing series characterised by equality of opportunity and fairness – in both technical and sporting terms. Those involved in the Porsche PAYCE Carrera Cup Australia (participants, i.e. teams with all employees and team members, Drivers, officials, organisation) make a significant contribution to how the Series is perceived – both internally and by the general public – and to the atmosphere in the Porsche PAYCE Carrera Cup Australia through their conduct and their communication.
- (b) All those involved are responsible for conducting themselves in such a way as to uphold and safeguard in the long term the professionalism that prevails in the Porsche PAYCE Carrera Cup Australia, as well as the esteem in which the Series and its participants are held by the general public. Moreover, fair and sporting competition represents an important safety aspect for all participants, and is intended to avoid risk factors.
- (c) For this reason, all those involved agree to acknowledge the philosophy of the Porsche PAYCE Carrera Cup Australia and to comply with the rules of conduct of the Series.
- (d) Both on and also adjacent to the race track, all those involved shall:
  - (i) treat the other participants, officials and organisers respectfully; and
  - (ii) follow the laws and the rules of the sport, and exemplify and promote fairness and the rules of conduct; and
  - (iii) neither express themselves or behave in an insulting, offensive or abusive way, nor tolerate such expressions or modes of conduct, either in direct conversations, interviews, etc. or in other communication, e. g. press releases, posts in social media, etc.; and
  - (iv) always behave in the interests of safety and permanently cooperate in efforts to reduce risks; and
  - (v) use resources in a sustainable way, giving priority to the well-being, safety and satisfaction of others before their own personal goal; and
  - (vi) always comply with the purpose of the sport; and
  - (vii) point out to other people who are involved if their conduct is not characterised by fairness, sportsmanship, respect and tolerance; and

- (viii) cooperate with all other persons involved so as to develop and improve the Series and its status further on a continuous basis.
- (e) As a consequence of failing to comply with the rules of conduct, participants who:
  - (i) (repeatedly) infringe against the Regulations; or
  - (ii) draw attention to themselves through unsporting behaviour on and adjacent to the track; or
  - (iii) express themselves about or behave in a disrespectful way towards other participants, officials, organisers, etc.; or
  - (iv) ignore the specifications, instructions, meetings of the Series Organisation and/or other official bodies in the context of the organisation and holding of an Event; or
  - (v) ignore agreements that have been reached (including between teams and Drivers) and do not meet obligations of performance; or
  - (vi) do not act in the interests of the sport and/or the recognisable objective of undertaking the activities seriously in accordance with the rules that have been acknowledged;
  - (vii) may be excluded from the Porsche PAYCE Carrera Cup Australia Series.
- (f) Continued participation in this Series may not be permitted until any fine imposed is paid in full.

## Appendix 1 AUTOMOBILE MARKINGS

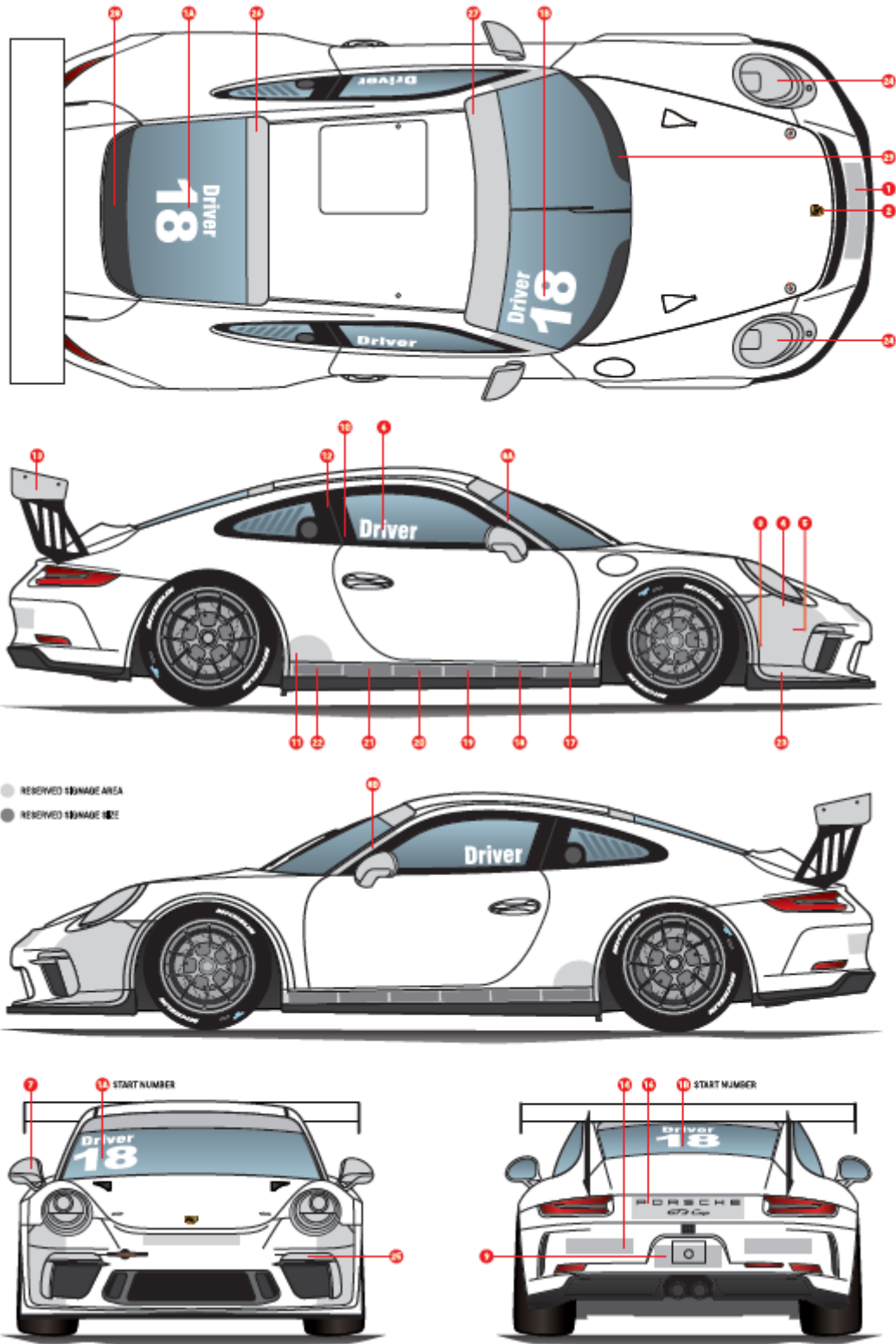

## Appendix 2 Fuel Container





## Appendix 3 In Car Camera Reserved Signage



The area indicated on the dash in white (400mm x 85mm) and the inside of the door coverings are allocated to a Competitor for the use of personal sponsors. No other competitor signage shall be permitted.



# 2020 Porsche PAYCE Carrera Cup Australia Series

## Technical Regulations

### T1 PREAMBLE

Unless expressly permitted in these Regulations, modification to the standard specification of the Automobile as supplied by Porsche Cars Australia (PCA) is strictly prohibited. In the event of any dispute, parts or specifications of the Automobile in question shall be compared against parts and/or specifications supplied by PCA. PCA reserves the right to update part numbers from time to time as they are superseded.

### T2 ELIGIBILITY

#### T2.1 Eligible Automobiles

- (a) Only Porsche 911 GT3 Cup (Type 991 II) Automobiles purchased new from PCA with a Race Vehicle Authorization Certificate (RVAC) shall be eligible to compete in the 2020 Porsche PAYCE Carrera Cup Australia Series (Series). Each Automobile must, without exception, comply with these Technical Regulations throughout all official on-track activities:
  - (i) at a Round of the Series; and
  - (ii) at an approved test day (refer [S17.2](#)).
- (b) See Automobile specifications at Appendix 1.

#### T2.2 Examination for Eligibility

- (a) The presentation of an Automobile for participation in any Round of the Series shall be deemed to be an implicit statement by the Competitor of conformity with all the Rules in these Technical Regulations.
- (b) Should the Technical Delegate (TD) suspect at any time that an Automobile does not comply with these Regulations, the Competitor, or nominated representative, must be so advised and given the opportunity to comment on the suspected or alleged ineligibility.
- (c) Any comment so made may be recorded by the TD, and subsequently may be presented at any Stewards' Inquiry or Hearing.
- (d) Should the TD fail to receive an adequate comment on the suspected or alleged ineligibility, which the TD alone has sole discretion to consider as adequate or satisfactory, the TD may require the Automobile to be impounded and examined, including such dismantling as may be necessary, to determine the points of eligibility in question.

- (e) At the discretion of the Stewards and/or the TD, any component, part or Automobile may be sealed by the TD for later examination.

### **T3 SCRUTINY**

#### **T3.1 Onus on Competitor**

The onus is on the Competitor, or their nominated representative, to present their Automobile for scrutiny at the appropriate times, in a complete and finished state, in 'ready to race' condition including all markings and seals on the Automobile in accordance with the Sporting Regulations and Schedule K of the Motorsport Australia Manual and an operating timing transmitter in position on the Automobile.

#### **T3.2 Targeted Scrutiny**

Scrutiny at each Round of the Series shall be conducted according to the Targeted Scrutiny Procedures published by Motorsport Australia.

### **T4 COCKPIT**

#### **T4.1 Safety Cage**

The safety cage as welded into the Automobile is mandatory and must not be modified. The DMSB Safety Cage certificate for the individual Automobile must be presented upon demand to the scrutineers.

#### **T4.2 Windscreen**

It is not permitted to fit after-market windscreen heater strips. It is permitted to fit an optional heated windscreen, part # 991.541.911.00.HTW and windshield protection tear-offs.

#### **T4.3 Pit Lane Speed Limiter (Limiter)**

The Limiter must be activated at all times whilst the Automobile is moving in Pit Lane.

**Note:** Regardless of the Limiter, each Driver always remains responsible for ensuring that the pit lane speed limit is not exceeded.

#### **T4.4 Seat**

- (a) The Driver's seat and mounting bracket/s must be as supplied by Porsche and of a type homologated by the FIA 8862-2009 standard.
- (b) The original mounting (track) must be retained.
- (c) Optional individual seat padding systems as supplied by PCA or their nominated representative may be used. Seating inserts must be covered in a flame retardant material to the same padding required in the FIA 8862-2009 Standard.
- (d) The floor of the Automobile must not be modified in any way and the original seat mounting holes must be used.

#### **T4.5 Safety Harness**

A minimum '5 point' safety harness meeting the FIA 8853/98 standard which is suitable for use with a Frontal Head Restraint system is compulsory.

#### **T4.6 Window Net**

Each Automobile must be fitted with the after sales window net as specified below and mounted in compliance with the Porsche AG mounting instructions.

Description	Part Number
AS Safety Net Side	9917225217A
F-Kit Holder Seat Belt	917225117C
AS Safety Net Centre	9917225237A

#### **T4.7 Cool Suit Associated Components**

- (a) It is permitted to fit a cool suit system to the Automobile.
- (b) The cool suit system may run off the Automobile's electrical system.
- (c) The cool suit system may form part of the ballast of the Automobile.
- (d) The mounting of cool suit associated component hardware is to be located wholly within the cockpit. The cool suit cooler unit must only be mounted in conjunction with the ballast mounting plate supplied by Porsche.

#### **T4.8 Drink Bottle**

A drink bottle may be fitted for the Driver's hydration. The bottle and associated plumbing are to be located wholly within the cockpit and must not exceed two (2) litres in capacity. Only one (1) drink bottle is permitted per Automobile. The drink bottle must only be of proprietary manufacture and securely mounted and to the satisfaction of the TD.

#### **T4.9 In-Car Cameras**

Other than those fitted by personnel Authorized by the television network for TV production purposes and approved by the CM, only the VBox Video HD2 camera system as determined by the CM is permitted. The installation of the camera and associated components must be to the satisfaction of the TD and Chief Scrutineer.

#### **T4.10 Timing Transmitter**

The location of the Dorian Data 1 transmitter shall be in the recessed section of the left rear floor pan. Mounted to the plate provided in the area to the right of the rear air jack. See diagram attached at [Appendix 2](#).

#### **T4.11 Fire Extinguisher**

The fire extinguishing system, compliant with FIA Article 253.7.2 of Appendix J to the International Sporting Code, as supplied originally with the Automobile and its installation position must remain unchanged.

#### **T4.12 Side and rear windows**

Only the genuine Porsche 911 GT3 Cup (Type 991 II) side and rear windows, as originally supplied, are permitted. Part numbers are as follows:

<b>Location</b>	<b>Part Number</b>
Door Window Left	991.542.511.8E
Door Window Right	991.542.512.8E
Rear Side Window Left	991.543.511.8G
Rear Side Window Right	991.543.512.8G
Rear Window	991.545.111.8F

#### **T4.13 Coachwork**

The Coachwork must remain as supplied by the factory. For clarification, it is not permitted to alter the rear wheel housings.

#### **T4.14 Ventilation**

Ventilation ducts must remain as originally supplied except that it is permitted to cover the front bonnet Driver ventilation duct and/or the rear side window openings with clear tape, only when the Automobile is fitted with wet weather tyres or by approval of the TD.

#### **T4.15 Air Intake Blanking**

It is not permitted for air intakes in the front bumper bar to be partially or completely blanked.

### **T5 TRANSMISSION/DIFFERENTIAL**

- (a) The ramp angles are 52° (drive) and 30° (coast), refer to [Appendix 7](#).
- (b) The minimum locking torque of the differential measured at the wheel nut with a blocked meshing gear is 65Nm.

### **T6 ENGINE TYPE**

Unless with prior written approval of the CM, the engine must respect the year of the Automobile at all times, refer to [Appendix 1](#).

### **T7 ENGINE AND TRANSMISSION REPAIRS**

#### **T7.1 Duty of Notification**

- (a) The Competitor must notify the CM, in writing, of any required repairs to the below listed components by submitting the Request for Repairs Form. (Sample shown in [Appendix 3](#)).
- (b) No work to these components is permitted to be undertaken by a Competitor unless prior written confirmation has been received from the CM. The CM reserves the right to inspect any Automobile prior to this authority being granted.
- (c) Any breach of the requirement for notification shall be referred to the Stewards.

## **T7.2 Repairs**

- (a) All work involving the following items and/or breaking of seals is only to be conducted once formal written approval is given by the TD, refer [Appendix 3](#)
  - (i) Crankcase
  - (ii) Crankshaft
  - (iii) Pistons
  - (iv) Cylinder head
  - (v) Camshaft
  - (vi) Gearbox
  - (vii) Differential
- (b) Once the CM and the TD are satisfied that the appropriate procedures for repair have been complied with, the TD shall fit the required seals.
- (c) The above protocol is to ensure continuity and parity between Automobiles.
- (d) Any breach of the above direction shall be referred to the Stewards.

## **T8 SEALS**

- (a) The CM shall supply and fit engine and gearbox seals to each Automobile determined to be eligible to compete. These seals shall be fitted to the camshaft housing covers on the right and left hand sides of the engine (2 seals), differential housing and gearbox housing (2 seals).
- (b) The ultimate responsibility to ensure all correct seals are fitted prior to any track activity rests solely with the Competitor.
- (c) The Competitor of an Automobile found not to have the correct seals fitted or if it is determined the seal has been tampered with, may be referred to the Stewards.
- (d) The Competitor of an Automobile found not to have seals fitted (save that written advice has been forwarded to the CM and the CM has given written permission for the seals to be removed) may be referred to the Stewards.
- (e) At all times, the TD shall be a judge of fact in respect of any seals fitted to an Automobile.

## **T9 SUSPENSION**

### **T9.1 Suspension**

- (a) The suspension must only be adjusted within the existing tolerances. All original parts, including replacement parts, must be retained in their original fitted location. The maximum permissible thickness of shims on the control arms are:

	Front Axle	Rear Axle
Type 991 II (MY17-19)	18 mm	15mm
Phillip Island Circuit Only		
Type 991 II (MY17-19)	14 mm	12 mm

- (b) The diagonal link mounting points on the front control arms must be retained at the factory position (shortest wheel base). Middle position is not permitted.

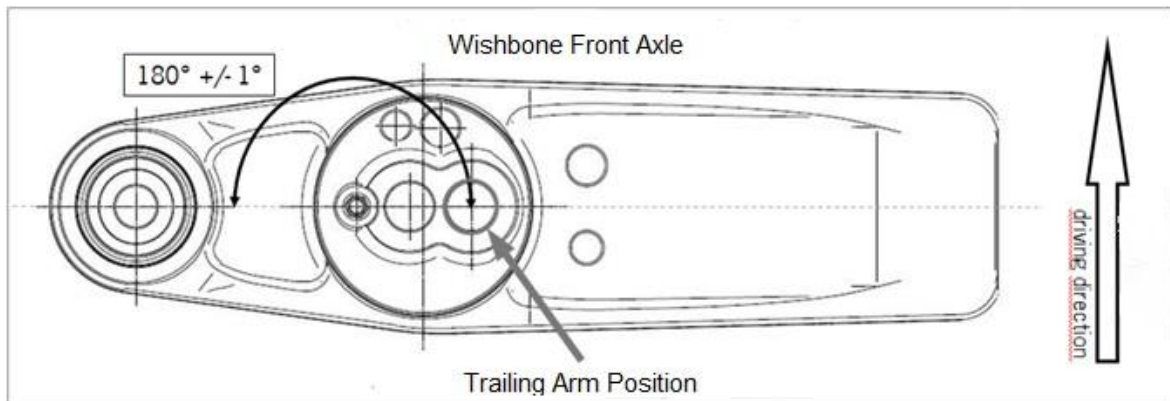

### T9.2 Dampers and Springs

- (a) Only the factory-installed Sachs shock absorbers and H&R chassis springs, as per the table below, in their original condition are permitted to be used.

	Front	Rear
Sachs Damper	991.343.045.8D	991.333.051.8A
Main 240/60/120	991 343 531 8C	
Tender 75/60/42	996 343 537 90	
Main 260/60/130		991 333 531 8C
Tender 80/60/60		997 333 537 90

- (b) The original delivery condition of the bump stops of the front and rear dampers must not be modified in any way.
- (c) The TD may, at any time, request the removal of the dampers and springs from any Automobile for the purpose of testing and/or eligibility checking. The TD may require the dampers and springs to be taken to another location for testing.

### T9.3 Ground Clearance

- (a) The minimum ground clearance of the ready-to-drive Automobile (with the Automobile ballasted as per T13 and fitted with slick tyres at 2.0 bar (29 psi) +/- 0.1 bar (1.45 psi) air pressure) must not be less than the specified dimension, as measured at the specified measuring points, at any time during an Event.
- (b) For the duration of an Event, the ground clearance of the front axle is to be a minimum of 78mm and the clearance at the rear axle a minimum of 100mm.
- (c) The measuring points are as below and are depicted in [Appendix 4](#):

- (i) Front Axle: mounting bolts (M14x120) of the cross member/bodywork in relation to the reference surface
- (ii) Rear Axle: machined surface on the side section of the rear axle in relation to the reference surface
- (d) The ground clearance may be changed within the existing adjustment range.
- (e) The minimum ground clearance of the ready-to-drive Automobile is checked using an appropriate height gauge for the axle to be measured. If the appropriate height gauge can be moved under the measuring points described above, this confirms compliance with the minimum height requirement.
- (f) Compliance shall be as determined by the TD.
- (g) Each Automobile that records a height less than the stipulated minimum shall incur a penalty. The penalty for the first breach shall be disqualification from the results of that session. The penalty for any subsequent breach of the minimum height may include disqualification from the Event.

#### **T9.4 Anti-Roll bars**

The disconnection of the anti-roll bars is permitted under the condition that no parts are removed from the Automobile. Only the seven anti-roll bar blade adjustment positions may be used.

## **T10 BRAKES**

The brake system and components must comply with [Appendix 1](#).

## **T11 TELEMETRY, DATA RECORDING SYSTEM AND ECU**

### **T11.1 Telemetry**

The use of telemetry is prohibited.

### **T11.2 Data Recording System**

- (a) The Cosworth data acquisition system as supplied originally with the Automobile shall be the only data acquisition system permitted.
- (b) This system must be installed as original without modification.
- (c) The Cosworth system is assigned to the VIN/Chassis Number and must not be exchanged unless otherwise approved by the CM.
- (d) Only Cosworth Toolset software may be used unless otherwise approved by the CM

### **T11.3 ECU and Wiring Loom**

- (a) The Bosch Motronic MS4.6 NG electronic control unit coded and sealed by PCA is the only unit to be used.

- (b) The Bosch Motronic MS4.6 NG electronic control unit including the complete wiring loom must be used without being changed.
- (c) The TD and or the TA reserve the right to check or exchange the Bosch electronic control unit.
- (d) The CM reserves the right to reprogram the Bosch electronic control units at any time during an Event. This is to ensure that the status of the program and data is identical for all participating Automobiles.

#### **T11.4 Verification – ECU Data Monitor**

- (a) At any time the TD may fit a data monitor to a competing Automobile. The ECU data monitor is supplied by the CM and the wiring harness is fitted standard to each Automobile.
- (b) Each Competitor is responsible for ensuring that the wiring and sensors that provide signals to the ECU data monitor are adequately maintained and remain working at all times.
- (c) Any cost of rectifying damage (whether accidental or otherwise) to the ECU data monitor while in the possession of a Competitor, is the responsibility of the Competitor and the cost of any damage shall be assessed by the CM.
- (d) The TD shall make all decisions in relation to all determinations regarding the installation and operation of the ECU data monitor and any interpretation arising there from.
- (e) ECU data logging by any Competitor and/or Driver is prohibited.

### **T12 WHEELS**

- (a) Only the wheels detailed in [Appendix 1](#) are allowed.
- (b) Each Competitor must have a minimum of three (3) full sets of wheels for each Automobile.
- (c) Each wheel must be fitted with original specified pressure and temperature sensors. Only the use of a valve cap that prevents the passage of air is permitted.

### **T13 RACING WEIGHT**

- (a) Subject to the provisions of Article [T4.7 \(c\)](#) of these Regulations each Automobile must achieve a minimum Racing Weight of 1313kg.
- (b) This weight shall consist of a minimum Automobile weight of 1228kg and minimum Driver weight of 85kg, including all personal equipment as recorded by the TD at the Driver's first Event of the Series.
- (c) A Driver equalisation weight shall be added to the minimum Automobile weight for any Driver weighing less than 85kg. For example, if a Driver's recorded weight is 83kg, the minimum Automobile weight shall be increased by 2 kg (driver equalisation weight) to 1230kg.



- (d) Any Driver equalisation weight or Automobile ballast weight must be fixed to the top of the mounting plate (part number 9915048477B) located in the designated fixing points in the position of the passenger seat to the floor of the cockpit in accordance with the image in [Appendix 6](#).
- (e) The camera weights (part number 99150484800 and 99150484801) as supplied by Porsche must be fitted to inboard mounting points on the underside of the mounting plate. The camera weight may be removed if the Automobile is fitted with an official camera system.
- (f) Weight may be checked after each official qualifying session and after each Series race on the scales provided by the CM at each venue. The weight recorded on these scales shall be considered to be fact and shall not be the subject of any Appeal or Protest.
- (g) Each Automobile that records a weight less than the stipulated minimums shall incur a penalty. The penalty for the first breach shall be disqualification from the results of that session. The penalty for any subsequent breach of the minimum weight may include disqualification from the Event.

## **T14 LUBRICANTS**

### **T14.1 Engine Oil**

- (a) Only Mobil 1 0W40 or Mobil 1 ESP X3 0W40 engine oils may be used in the engine at all times during any practice, qualifying or race.
- (b) Any addition of additives to the engine oil is prohibited.

### **T14.2 Gearbox Oil**

- (a) Only Mobil Lube 1 SHC 75W90 gear oil may be used in the gearbox at all times during any practice, qualifying or race.
- (b) Any addition of additives to the gearbox oil is prohibited.
- (c) There is to be a minimum of two point seven (2.7) litres of gearbox oil in the gearbox at all times.

### **T14.3 Oil Samples**

Random oil samples shall be taken during the season to ensure uniformity and the results of these oil samples shall be available to the respective Competitors.

## **T15 FUEL SYSTEM**

- (a) Each Automobile is required to arrive at the Event with no fuel in the tank.
- (b) Only the control fuel, as per S14(a), may be used at each Event.
- (c) The TD is entitled to take fuel samples from an Automobile competing at any time during an Event.

- (d) With the exception of ambient atmospheric air and the specified control fuel, no other substance may be added to the intake charge of the engine.

## **T16 REAR SPOILER**

The position of the rear spoiler profile may be changed within the prescribed adjustment range.

## **T17 FRONT LIP**

One version of front lip (closed) is approved for use on the Porsche 911GT3 Cup (Type 991 II) MY 17-18. Part # 9F0807061

## **T18 EXHAUST SYSTEM**

- (a) Exhaust System Nr 1 ('Supercup' system) is to be fitted as standard and Exhaust System Nr 2 (centre rear muffler and attachments) must be taken to all Rounds. Refer [Appendix 5](#).
- (b) Unless specified otherwise in the Event Regulations for a specific round, the Exhaust System to be fitted at each round must be as per the table below.

<b>Round</b>	<b>Circuit</b>	<b>Exhaust System</b>
1	Adelaide Parklands	Nr 1
2	Albert Park	Nr 1
3	Townsville	Nr 1
4	Hidden Valley	Nr 1
5	Sydney Motorsport Park	Nr 1
6	The Bend Motorsport Park	Nr 2
7	Mount Panorama	Nr 1
8	Surfers Paradise	Nr 1

## **T19 COOLING SYSTEM**

- (a) Where Glycol based corrosion protection is used, the volume of corrosion protection added must be limited to a maximum of 12% of the cooling system capacity.
- (b) The cooling system capacity is 22 litres, therefore the recommended fill method is 20 litres water plus 2 litres corrosion protection.
- (c) The TD may take samples and test concentration at any time during the Event
- (d) Corrosion protection Part Number 997 106 907 90 is recommended.

## **T20 STEERING**

- (a) Only one (1) hub extension, providing a 20mm extension (part number 99734728790) is permitted to be fitted between the steering quick coupler and the steering column.

## APPENDIX 1

2020 CARRERA CUP  
 APPROVED VEHICLE SPECIFICATION  
 RECOGNITION DOCUMENT

This form details the approved specifications of the Automobile model and shall be referred to as the "Recognition Document".

**Model Type:** 911 GT3 Cup (991 II)  
**Model Year:** 2017-2020 CUP

### T2.1. SECTION 1 - CHASSIS

1.1 CHASSIS FRAME		
Description:	Monocoque integrated chassis and body	
Manufacturer:	Porsche	
Material:	Aluminium-Steel Composite	
1.2 FRONT SUSPENSION		
Description:	McPherson Strut – Type Axle, Height Adjustable	
Spring medium:	Double Coil Springs (main and helper springs)	
Damper Type:	Sachs - Oil/Gas	Adjustable: No
Anti-sway bar:	Steel – Double Blade Type	Adjustable: Yes
Suspension adjustable:	Height – Via spring seat	Method: Thread
1.3 REAR SUSPENSION		
Description:	Multi Link with Solid Mounted Sub frame	
Spring medium:	Double Coil Springs (main and helper springs)	
Damper type:	Sachs - Oil/Gas	Adjustable: No
Anti-sway bar:	Steel – Double Blade Type	Adjustable: Yes
Suspension adjustable:	Height – Via spring seat	Method: Thread
1.4 STEERING		
Type:	Rack and Pinion	Make: Porsche
1.5 BRAKES		
	Front	Rear
Type:	Disc	Disc
Dimensions:	380 x 32	380 x 30
Part Nr:	Left: 9913511058A Right: 9913511068A	Left: 9913521078A Right: 9913521088A
Material of disc	Multi piece Steel	Multi piece Steel
No. Pistons per Caliper:	6	4
Actuation:	Hydraulic	Hydraulic
Caliper:	Porsche	Porsche
Adjustable bias	Yes	
Brake Booster Fitted	No	
Brake Pads	Brand: PFC Part No: 9913519428A	Brand: PFC Part No: 9913529428A

## T2.2. SECTION 2 - ENGINE

2.1 ENGINE			
Make:	Porsche		
Model:	MA178		
No. cylinders:	Six (6)	Configuration:	Flat
Cylinder Block-material:	Aluminium	Four Stroke:	Yes
Bore - Original:	102 mm	Max. allowed:	102mm
Stroke - original:	81.5mm	Max. allowed:	81.5mm
Capacity - original:	3996cc	Max. allowed:	3996cc
Cooling method:	Liquid		
2.2 CYLINDER HEAD			
Make:	Porsche		
No. of valves/cylinder-	Inlet: 2	Exhaust:	2
No. of ports total:	Inlet: 6	Exhaust:	6
No. of camshafts:	4	Drive:	Chain
Valve actuation:	Bucket with Hydraulic Lifters		
Spark plugs/cylinder:	1		
2.3 LUBRICATION			
Method:	Dry sump		
Oil tank location:	Front of Engine		
Dry sump pump type:	Gear		
Location:	Crankcase & Cylinder Heads		
Oil cooler standard:	Yes		
Location:	Engine		
2.4 IGNITION			
Type:	Coil on Plug		
Make:	Porsche		
2.5 FUEL FEED			
Fuel injection System	Model: MS4.6 NG	No: 991.618.603.8B	
Make:	Porsche	Type: Motronic/Bosch	
Injector:	Porsche	No: 9A11.092.892	

### T2.3. SECTION 3 - TRANSMISSION

3.1 CLUTCH		
Make:	Porsche	
Type:	Diaphragm	
No. of Plates:	3 Friction, 3 Pressure:	Assembly: 991.116.001.9A Friction: N/A
Components:	3 Friction Plates	Part No. 9971161139A
	2 Intermediate Plates	Part No. 9971161259A
	1 Pressure Plate	Part No. 9971161239A
	1 Basket	Part No. 9911160119A
Actuation:	Hydraulic	
3.2 TRANSMISSION		
Type:	Manual Sequential	Rear Wheel drive
Make:	Porsche	
Model:	G91/70	
No. forward speeds:	Six (6)	
1 – 13/41 3.154	2 – 17/40 2.353	3 – 19/36 1.895
4 – 19/29 1.526	5 – 24/30 1.250	6 – 34/35 1.029
3.3 FINAL DRIVE		
Diff. Make: Porsche	Ramp Angle = 52° Drive & 30° Coast	Part No. 9913320859L
Wheel drive method:	Hypoid crown wheel and pinion	
Ratios:	14/22 1.571	
Comments:	Oil cooler and pump fitted as standard	
3.4 TRANSMISSION SHAFTS (EXPOSED)		
Description:	CV type Shafts	
Part No:	9913320248L	
3.5 WHEELS AND TYRES		
Wheel type:	Porsche	Material: Aluminium
Fixture method:	Centre Lock	
	Front	Rear
Wheel Rim	Part No. 991.362.131.8A	Part No. 991.362.151.8A
	10.5J x 18 – 28mm offset	12J x 18 – 53mm offset

## T2.4. SECTION 4 - GENERAL

4.1 FUEL SYSTEM		
Tank Location:	Front	Capacity: 100 litres
Fuel pump, type and location:	Electric internal	Make: Porsche
4.2 ELECTRICAL SYSTEM		
Voltage:	12 volts negative ground	
Alternator fitted:	Part No. 9A260301800	
Battery Location:	Passenger foot well Part No. 999.611.070.12	
4.3 BODYWORK		
Type:	Coupe	Material: Smart Aluminium – steel Composite
4.4 DIMENSIONS		
Wheelbase:	2,456 mm +/- 15mm	
Overall length	4,577 mm	
Total width	1,978 mm	
Front overhang	1,046 mm	
Rear overhang (excluding wing)	1,075 mm	
4.5 PERMITTED MODIFICATIONS		
No modifications or deviations from the standard specification of the Automobile are permitted.		

## APPENDIX 2

### LOCATION OF DORIAN DATA 1 MICRO TIMING TRANSMITTER (FLOOR PAN REMOVED)





**APPENDIX 3**

**REQUEST FOR REPAIRS**

**Engine and Gearbox units must be returned to Porsche Cars Australia for repair.**

**Attention:**

Technical Manager  
Porsche Carrera Cup Australia

Team Name	
Contact Name	
Contact Phone Number	
Return Fax Number	
Competition Number	
Chassis Number	WP0ZZZ99Z
Date	

Reason for repairs (Include component)

Office Use Only
Date Received: _____
Approval Nr: _____
Approval Date: _____

**When completed please fax to 03 9473 0959 or email to [motorsport@porsche.com.au](mailto:motorsport@porsche.com.au)**

**APPENDIX 4**

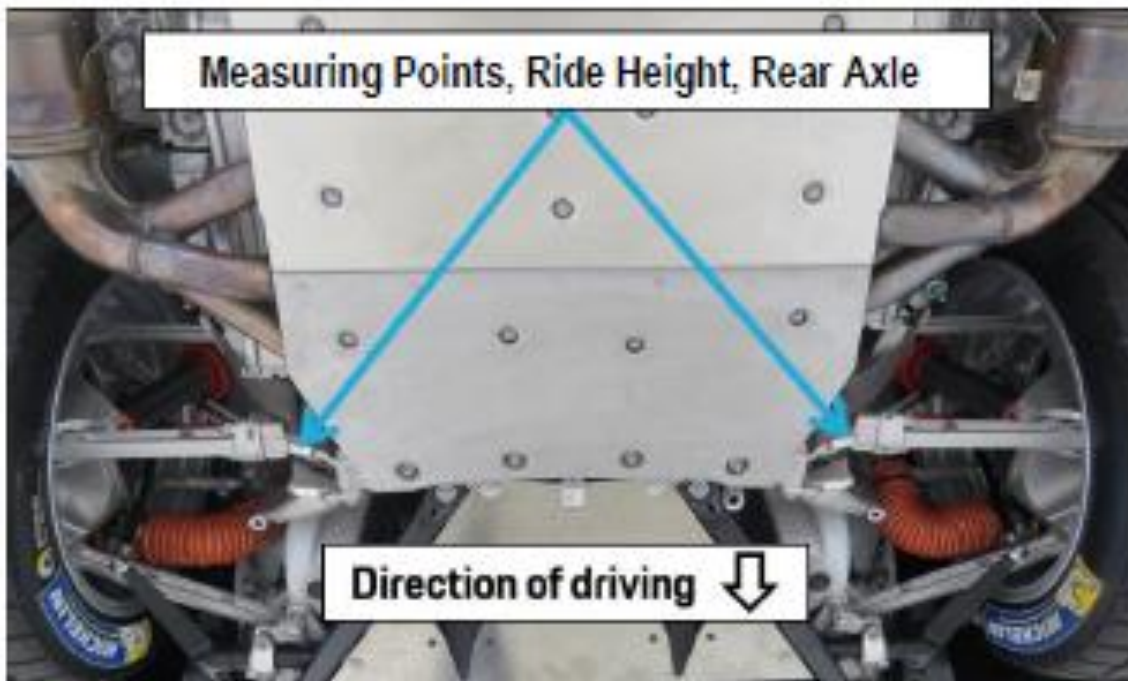
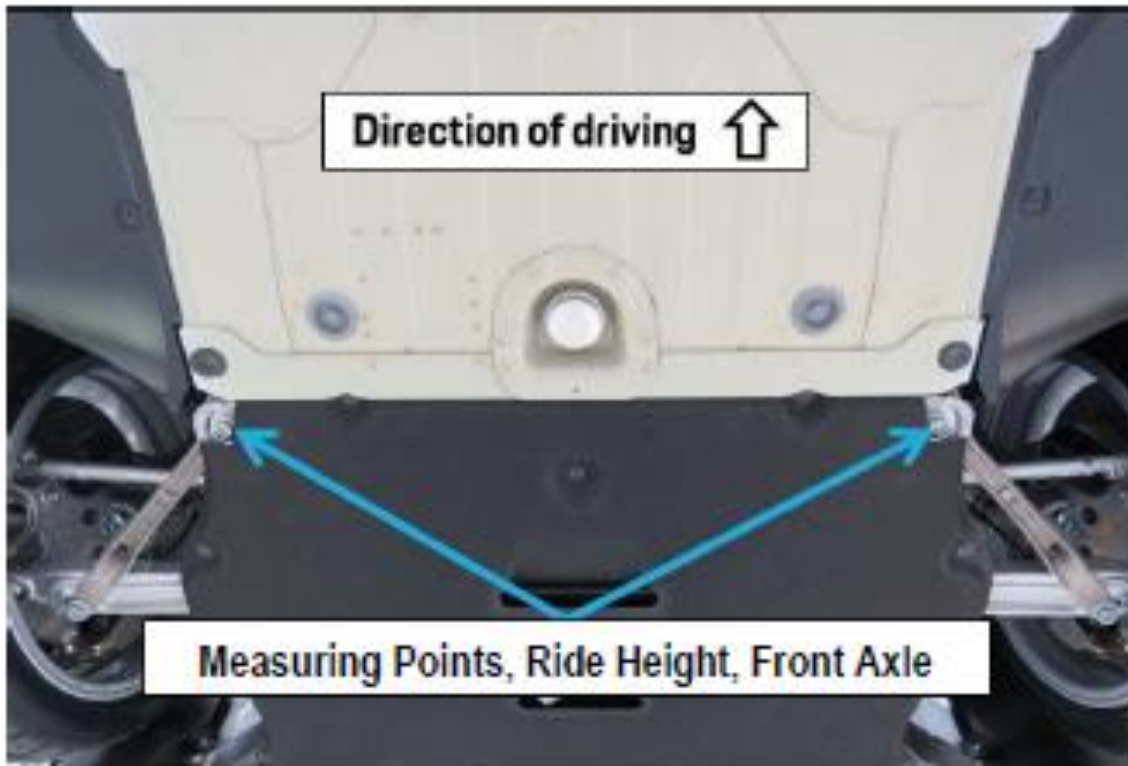

**APPENDIX 5**



Exhaust System Nr 1 'Supercup' system

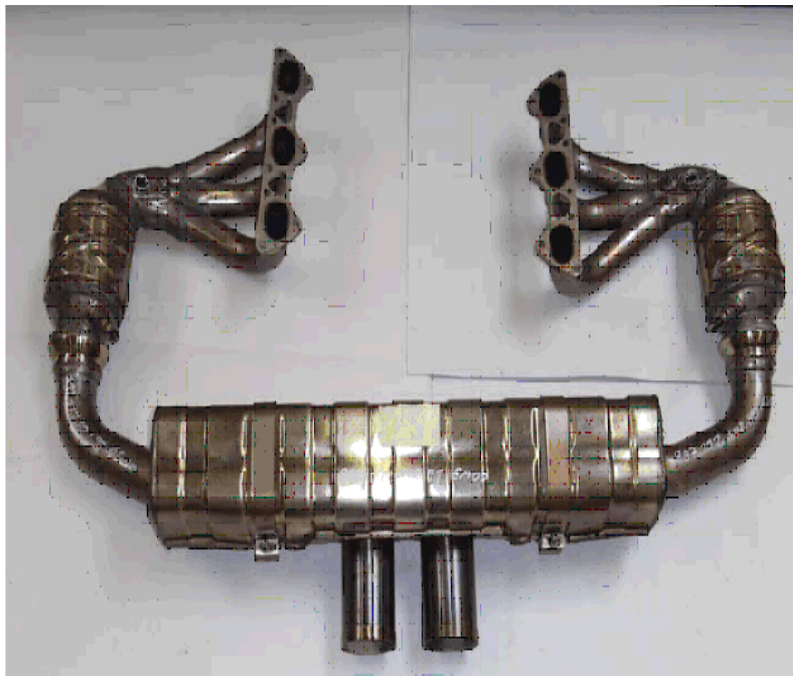

Exhaust

with centre rear muffler and attachments

System Nr 2

## APPENDIX 6

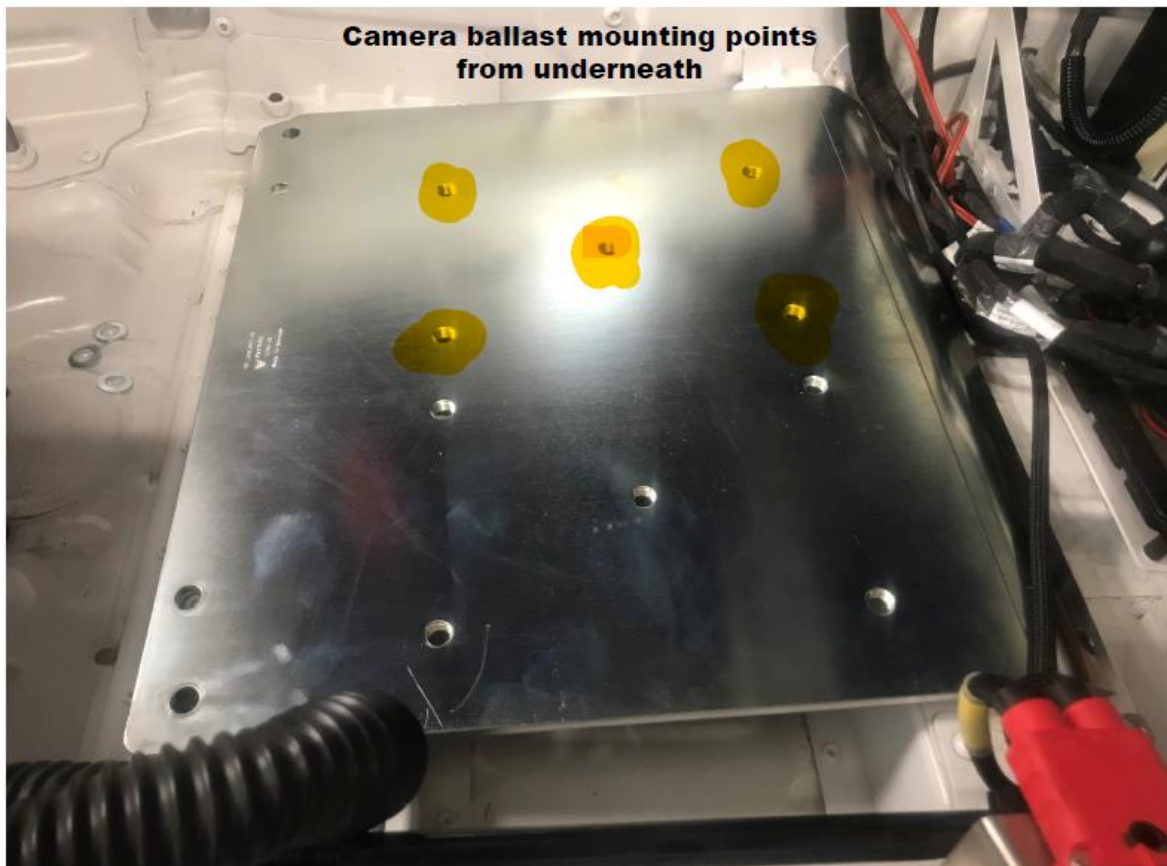



**APPENDIX 7**

